

# 110VAC MODE

TITLE: SUMP PUMP BATTERY BACKUP  
 AUTHOR: ROGER D. SECURA  
 FILE NAME: RELAY1.DWG  
 DATE: 2-12-06

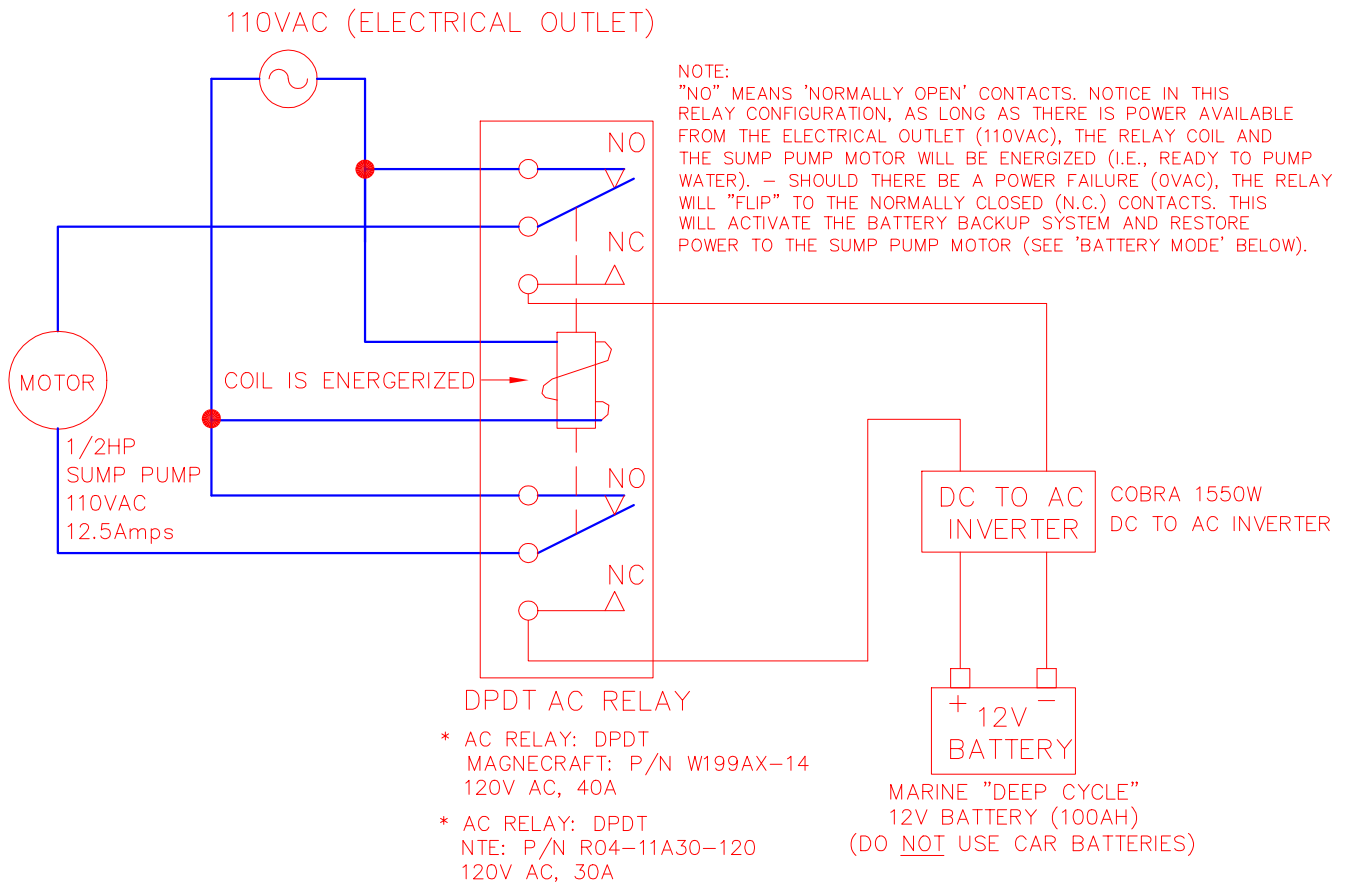

# BATTERY MODE

